

B STRIKE INSTALLATION / INSTALLATION DE LA GÂCHE

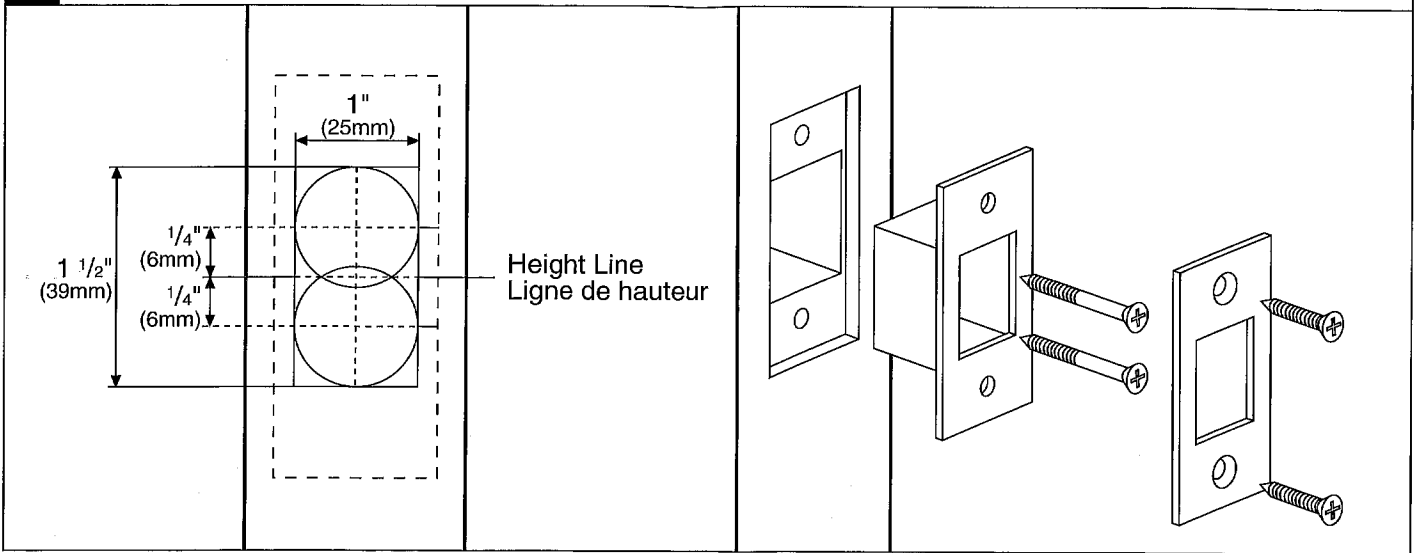

C CHANGING BACKSET OF THE BOLT / MODIFICATION DU RETRAIT DU PÊNE

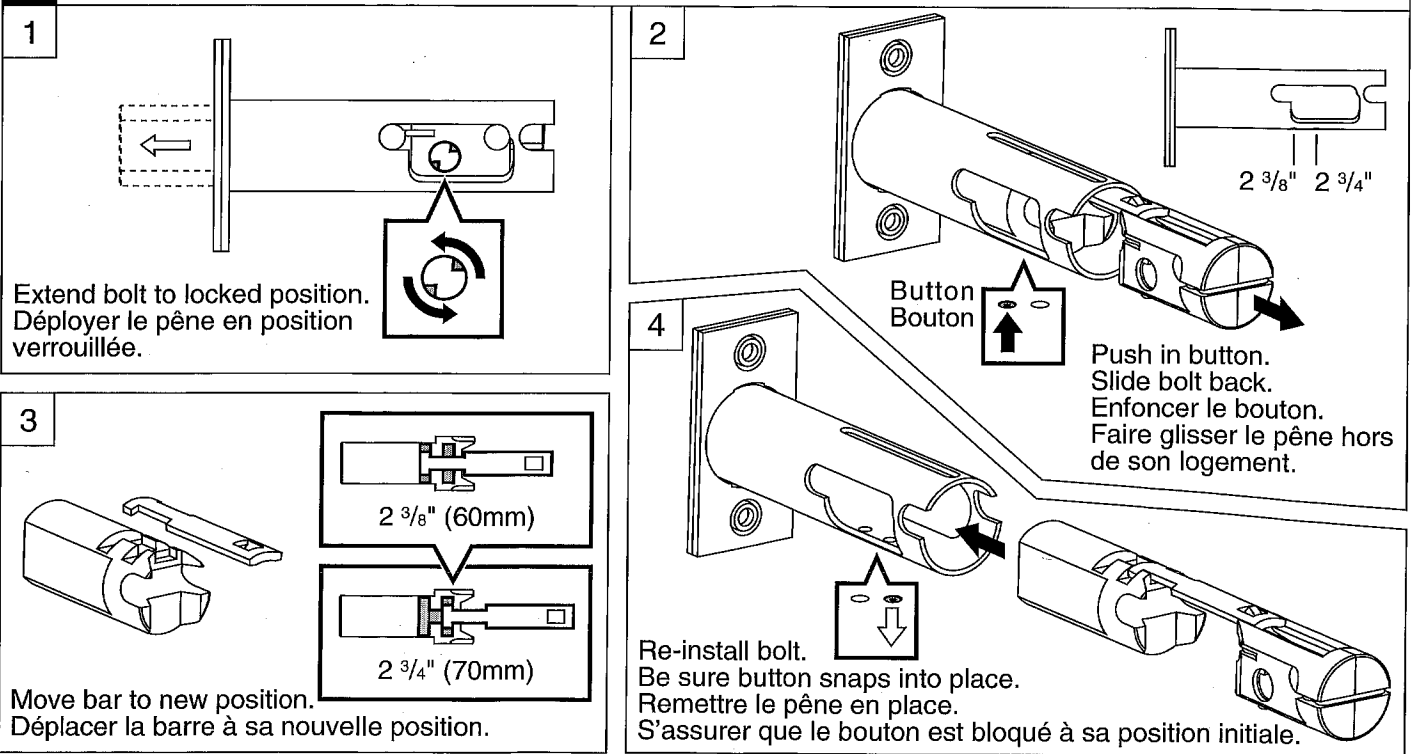

D ADAPTER RINGS / RONDELLES D'ADAPTATION

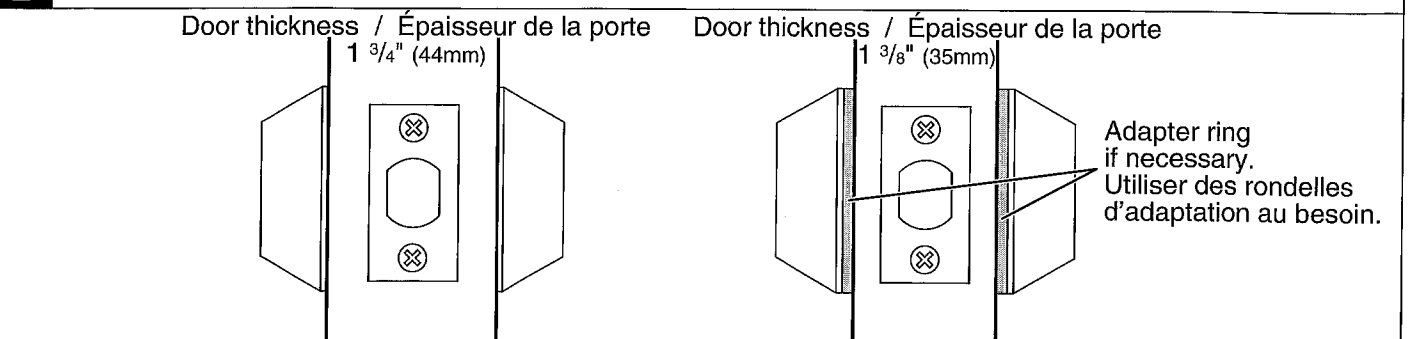

A INSTALLATION OF THE BOLT AND CYLINDERS / INSTALLATION DU PÊNE ET DES CYLINDRES

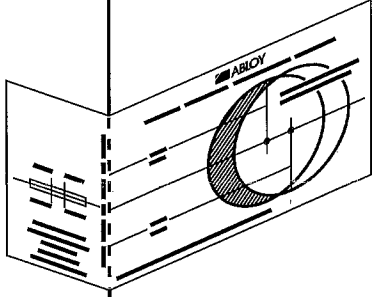
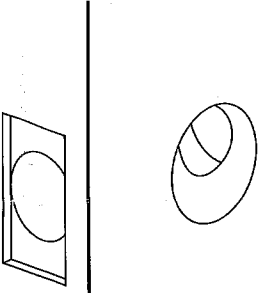
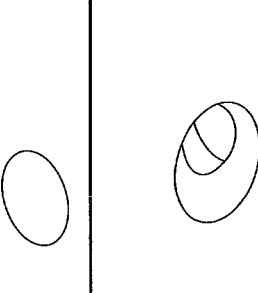
1	 <p>Use template included. Utiliser le gabarit fourni.</p>	2	Standard Bolt Pêne standard		Drive-In Bolt Pêne encastré	
----------	---	----------	--------------------------------	--	--------------------------------	---

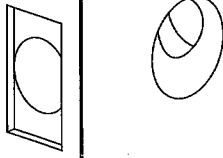
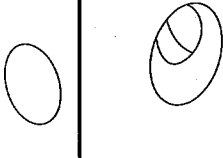
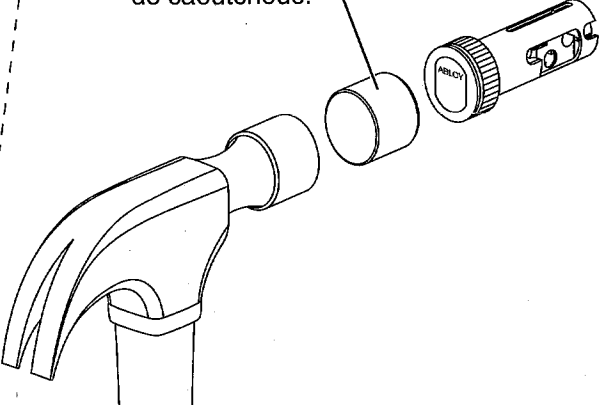
3	Standard Bolt Pêne standard		Drive-In Bolt Pêne encastré	
Piece of wood, plastic or rubber. Morceau de bois, de plastique ou de caoutchouc.				
				

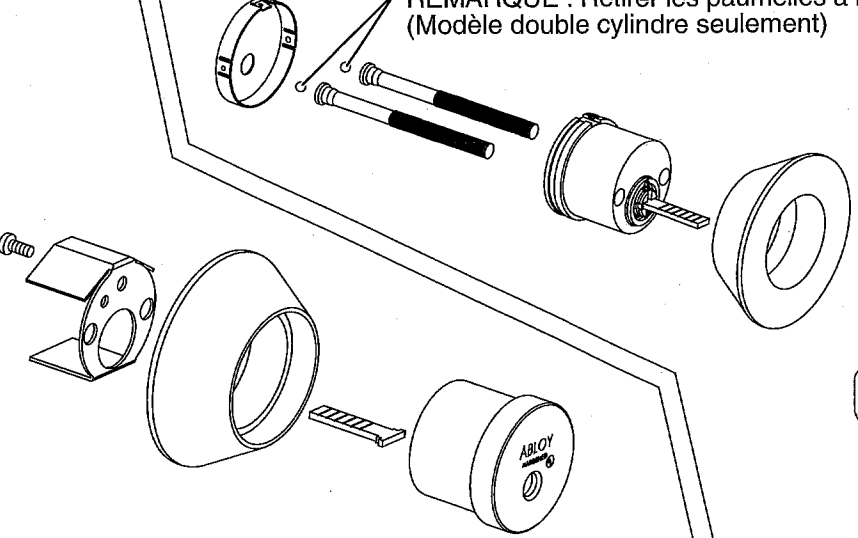
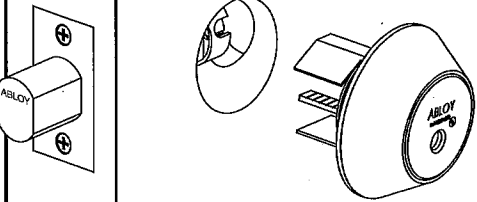
4	5	NOTE: Removing ball bearings will require extreme measures. (Double cylinder model only) REMARQUE : Retirer les paumelles à billes avec la plus grande précaution. (Modèle double cylindre seulement)
		
		

ABLOY®

TUBULAR DEADBOLT INSTALLATION TEMPLATE

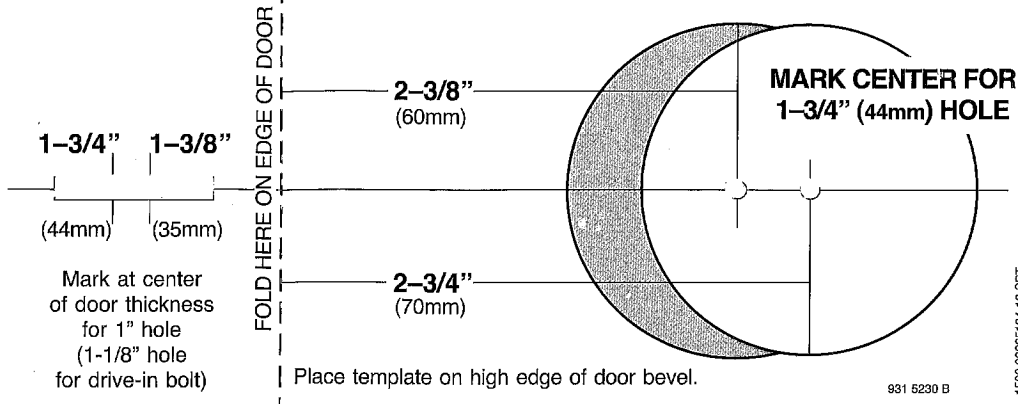

Mark at center
of door thickness
for 1" hole
(1-1/8" hole
for drive-in bolt)

931 5230 B

1500-09225134-12 SPT